

BULLETIN 360

October 2009

# Twin City Fan & Blower

## *HIGH EFFICIENCY PLUG FANS*

**TYPE BFPL**



# BFPL High Efficiency Plug Fans

BFPL plug fans from Twin City Fan & Blower are compact, versatile and offer the highest efficiency in the industry. Their versatility allows them to be used for air circulation in a variety of commercial and industrial applications including air curtains, air heaters, ceiling, wall, and floor panel plenums, degreasers, dryers, dust collectors, evaporators, freezers, kilns, ovens, packaged air handlers, parts washers, pent-houses, smoke houses, space heaters, spray booths, and other high temperature applications.

Plug fans are housed in the customer's enclosure in applications where the system plenum acts as the fan housing. This configuration saves space since connecting ductwork and motor support pedestals are generally not needed. More space savings can be obtained by utilizing the wheel compartment as a pressurized chamber in lieu of a fan scroll. The use of multiple discharges from the pressurized chamber allows for additional savings by reducing ducting requirements.



*Class III w/4"  
Insulated Plug and High Temperature Aluminum Paint*

*Class II w/  
OSHA Belt Guard*



BFPL plug fans feature SWSI backward curved, non-overloading, single thickness airfoil type wheels. The unique wheel offers increased efficiency over competitor's airfoil blade designs yet can handle airstreams not conducive to traditional hollow airfoil shapes.

The plug fan's motor and drive are protected from high temperatures by the customer's chamber wall or the optional 4" or 6" insulated plug. The motor and drive are mounted to the plug panel which may be bolted or welded in place. The plug assembly may be mounted with the shaft in either the vertical or horizontal position for maximum flexibility. Horizontal construction is standard. Vertical mounting can be provided when specified. An all welded housing and an integral inlet cone are available as options.

## Performance Comparison

Type BFPL Plug Fans are designed to maximize efficiency. This is illustrated by the following chart which compares the new BFPL Plug Fan and other manufacturers' airfoil (AF) and backward inclined (BI) fans.

*Nominal 36" Wheel Diameter*

CFM	SP	MANUFACTURER	RPM	BHP	SE%
23000	3.5"	Twin City BFPL	1057	16.39	77.3
		Manufacturer "A" AF	1107	16.60	76.3
		Manufacturer "A" BI	1005	17.50	72.4
		Manufacturer "B" AF	971	17.94	70.6
33000	5"	Twin City BFPL	1409	35.28	73.6
		Manufacturer "A" AF	1475	36.50	71.1
		Manufacturer "A" BI	1324	38.30	67.8
		Manufacturer "B" AF	1295	40.81	63.6

*Nominal 44" Wheel Diameter*

CFM	SP	MANUFACTURER	RPM	BHP	SE%
30000	2.5"	Twin City BFPL	717	15.28	77.2
		Manufacturer "A" AF	783	15.60	75.6
		Manufacturer "A" BI	713	16.50	71.5
		Manufacturer "B" AF	725	17.46	67.6
47000	4"	Twin City BFPL	1032	40.64	72.8
		Manufacturer "A" AF	1132	43.30	68.3
		Manufacturer "A" BI	1015	45.20	65.4
		Manufacturer "B" AF	1054	50.00	59.2

©2002, 2003 Twin City Fan & Blower. All rights reserved throughout the world.

Bulletin illustrations cover the general appearance of Twin City Fan & Blower products at the time of publication and we reserve the right to make changes in design and construction at any time without notice.

# Construction Features

## Plug Panel

Constructed of minimum 7-gauge steel with formed flanges to maintain flatness and rigidity. Panel is prepunched for bolt mounting. Panel assembly may also be welded in place. The “cross frame” bearing support is designed for maximum stability and load spreading. Bearings are serviceable without disassembly of panel or frame.

## Plug Assembly

Available for both horizontal and vertical applications. Horizontal construction is standard. Vertical construction will be provided when specified.

## Adjustable Motor Base

The motor base is standard with leveling and tension adjustment to ensure proper drive belt alignment. The motor base is heavy-gauge steel and prepunched to accept the standard motor frame specified.

## Wheels

Wheels are assembled of die-formed, matched components, continuously welded to both back plate and rim. Wheels are statically and dynamically balanced.

## Inlet Cones

Heavy-gauge and spun to match the wheel intake rim to insure smooth airflow. Inlet cone flange is prepunched for mounting. Inlet cones are shipped loose as standard. An integral inlet cone is optional.



*Class III Adjustable  
Motor Base*

## Shafts

Standard shaft diameters are sized for plug thicknesses to 6 inches and 1000°F operation.

## Bearings

Either ball or spherical roller, heavy duty, self-aligning, pillow block type bearings are provided. Bearing selection is based on L-10 minimum life of 40,000 hours or average life of 200,000 hours. Split roller bearings are not recommended.

# Typical Installations

Mounting is accomplished by providing a hole larger than the wheel diameter through the chamber wall. The wheel, shaft, motor, and drive assembly is then positioned to the inlet cone (mounted in opposite wall) and secured in place. See Figure A.

Another method is to provide a hole sized only for the wheel drive shaft. The wheel is then positioned through the opening for the inlet cone after the drive and panel assembly has been securely mounted. See Figure B.

Plug fans may be applied with open wheel (unhoused) or with a housing as shown in Figure C. Performance data in this bulletin is for unhoused wheel application.

**Walls must be designed to support the dynamic loads of the fan without resonance to eliminate vibration and bearing failure.**

*Plenum System*

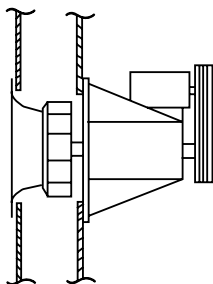
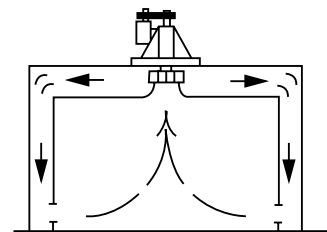

*Figure A*

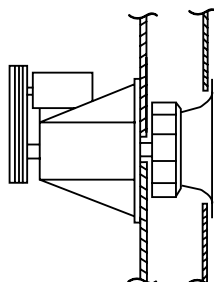

*Figure B*

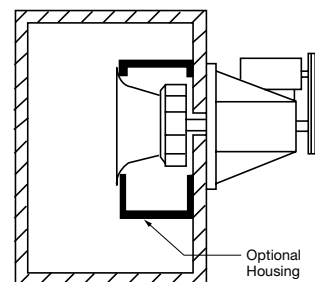

*Figure C*

# Optional Construction

## High Temperature Construction

**301-500°F:** Includes high temperature grease, expansion and non-expansion bearings, ceramic shaft seal and shaft cooler.

**501-800°F:** Includes the modifications above with the addition of high temperature aluminum paint. Minimum 4" insulation is required and is available as an optional item from TCF. Be sure to apply derating factors for high temperature construction.

**801-1000°F:** Includes the modifications above with the addition of 316 stainless steel wheel and shaft. Also includes shaft extension for the required 6" insulation. 6" insulated plug is available as an optional item. Be sure to apply stainless steel derating factors for temperature.

## Insulated Plug

Protects motor and drive components from heat. An insulated plug is recommended for temperatures above 300°F. Available in 2", 4" and 6" thicknesses. Special thicknesses to match customer's insulated wall are available. Plug is assembled to mounting panel when ordered. See Table 1 on page 5 for maximum RPMs.

## All Welded Housing

Heavy-gauge steel housing is provided with wheel opening on each side and weld studs on the inlet side for cone mounting. Specify rotation and discharge as viewed from drive side to insure proper stud placement. Housing supports and attachments for wall mounting to be provided by others. See page 14 for dimensions.

## Variable Inlet Vanes

Vane blades are cantilever design or center supported, equipped with permanently lubricated bearings and ball joints for smooth and easy operation. Vane assemblies are external type for sizes 121 through 161 and nested for sizes 181 through 491. Standard inlet vanes are applicable to 300°F. Consult factory for higher temperatures.

## Spark Resistant Construction

Fan applications may involve the handling of potentially explosive or flammable particles, fumes or vapors. Such applications require careful consideration by the system designer to insure the safe handling of such gases. Twin City Fan & Blower offers the following classifications of spark resistant construction per AMCA Standard 99-0401-86. It is the specifier or the user's responsibility to specify the type of spark resistant construction with full recognition of the potential hazards and the degree of protection required.

**Type C** - The fan shall be so constructed that a shift of the wheel or shaft will not permit two ferrous parts of the fan to rub or strike.

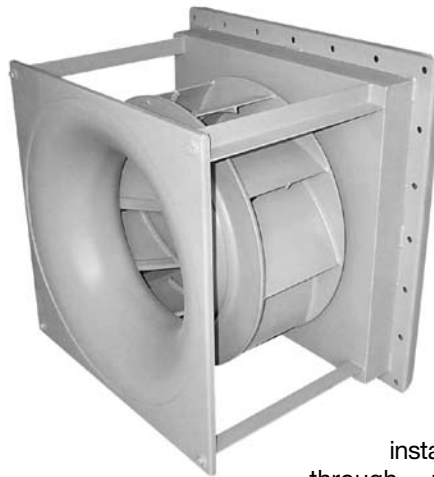

## Integral Inlet Cone Assembly

Includes four pieces of angle, welded to the insulated plug or mounting panel, which serve to pre-align the inlet funnel within the wheel. The entire unit can be

installed or removed through the same hole in the customer's enclosure, without the need for additional mounting or alignment of the inlet cone.

## Shallow Depth Inlet Cone

The shallow inlet cone can shorten the overall length of the plug fan, providing extra space where needed. See dimensional data on page 14 for comparison between standard inlet cone and the shallow depth cone. Fan performance in smaller sizes must be derated for the modification. See Table 3 for performance derates.

# Mounting Arrangements

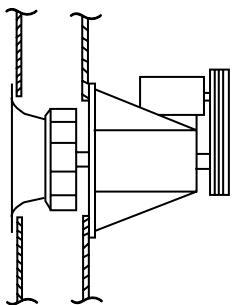

*Horizontal*

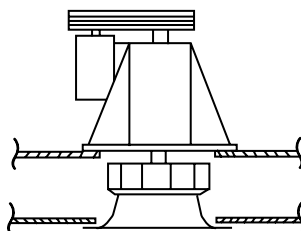

*Vertical Up*

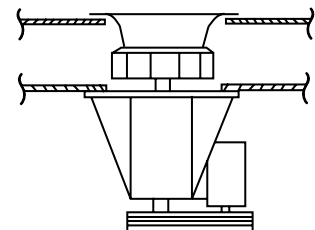

*Vertical Down*

# Engineering Data

To ensure proper motor selection, consideration must be given to starting torque requirements (fan wheel inertia  $WR^2$ ) along with the operating BHP. Table 1 lists the  $WR^2$  factors for different wheel sizes to be used in evaluating the capability of a selected motor.

In some cases it may be necessary to provide a larger horsepower motor, even though it may not be dictated by the operating BHP, to bring the fan to speed.

Table 1. Maximum Fan RPMs, Wheel Weights and  $WR^2$

FAN SIZE	CLASS II					CLASS III				
	MAXIMUM RPM			WHEEL WT. (LBS.)	$WR^2$ (LBS-FT <sup>2</sup> )	MAXIMUM RPM			WHEEL WT. (LBS.)	$WR^2$ (LBS-FT <sup>2</sup> )
	NO PLUG	4" PLUG	6" PLUG			NO PLUG	4" PLUG	6" PLUG		
121	3778	3000	3000	21	3	-	-	-	-	-
141	3352	3000	2875	24	4	-	-	-	-	-
161	2975	2975	2425	32	7	-	-	-	-	-
181	2644	2644	2275	52	13	3557	3000	3000	62	14
201	2380	2380	2200	58	18	3202	3000	2900	70	20
221	2125	2125	1850	75	31	2859	2859	2650	84	33
251	1889	1889	1700	96	50	2541	2541	2303	111	51
281	1676	1676	1676	140	94	2255	2255	1936	156	104
321	1487	1487	1487	173	152	2001	2001	1729	195	167
351	1322	1322	1322	211	241	1779	1779	1483	236	266
391	1190	1190	1190	254	376	1601	1601	1578	283	413
441	1062	1062	1062	361	613	1429	1429	1429	482	880
491	952	952	952	465	1025	1281	1281	1281	613	1450

Table 2. Bare Fan and Accessory Weights

FAN SIZE	APPROXIMATE WEIGHTS (LBS.)				
	BARE FAN		INSULATED PLUG	HOUSING	INLET VANES
	CLASS II	CLASS III			
121	140	-	25	24	45
141	145	-	25	30	52
161	185	-	32	44	58
181	208	444	32	65	29
201	221	470	32	79	33
221	235	513	35	97	38
251	240	594	35	117	40
281	323	756	40	143	45
321	388	990	55	287	50
351	430	1118	55	350	50
391	575	1467	75	428	55
441	639	1745	75	522	60
491	950	1900	95	634	65

Table 3. Shallow Inlet Cone Derates

FAN SIZE	INCREASE DESIGN SPEED BY	INCREASE DESIGN BHP BY
121 - 141	Not Available	Not Available
161 - 201	2%	4%
221 - 491	0%	0%

NOTE: Maximum RPMs in Table 1 cannot be exceeded.

Table 4. High Temperature Applications

TEMP. RANGE	BEARING TYPE	LUBRICATION	OTHER REQUIREMENTS
TO 300°F	BALL OR ROLLER	GREASE	STANDARD CONSTRUCTION
301 TO 500°F	EXPANSION AND NON-EXPANSION	HIGH TEMPERATURE GREASE	CERAMIC SHAFT SEAL, SHAFT COOLER
501 TO 800°F	EXPANSION AND NON-EXPANSION	HIGH TEMPERATURE GREASE	HIGH TEMPERATURE ALUMINUM PAINT 4" MINIMUM INSULATION REQUIRED BY TCF OR CUSTOMER CERAMIC SHAFT SEAL, SHAFT COOLER
801 TO 1000°F	EXPANSION AND NON-EXPANSION	HIGH TEMPERATURE GREASE	316 STAINLESS STEEL WHEEL AND SHAFT 6" MINIMUM INSULATION REQUIRED BY TCF OR CUSTOMER HIGH TEMPERATURE ALUMINUM PAINT CERAMIC SHAFT SEAL, SHAFT COOLER

# Engineering Data

Figure 1. Wheel and Plenum Arrangement

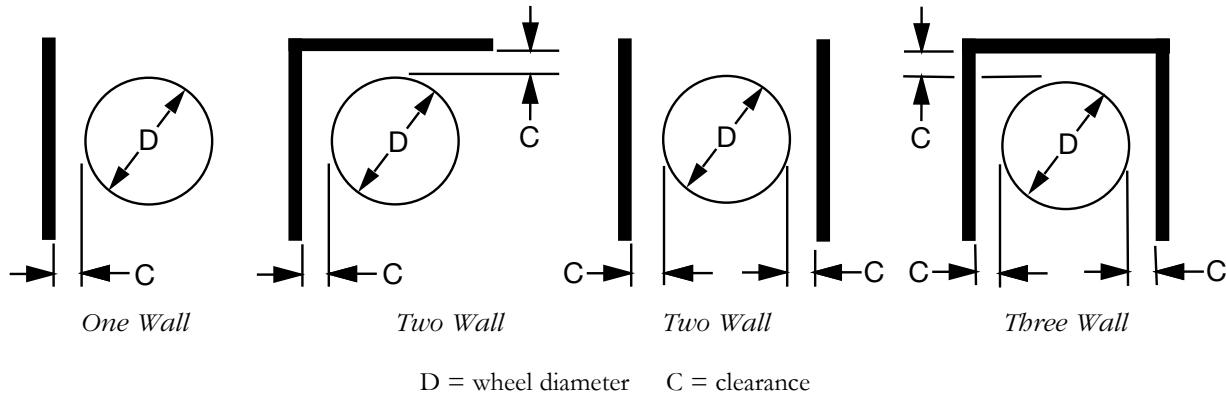

Table 5. Wall Proximity Factors

% WOV	FACTOR	C = D/8			C = D/4			C = D/2		
		ONE WALL	TWO WALL	THREE WALL	ONE WALL	TWO WALL	THREE WALL	ONE WALL	TWO WALL	THREE WALL
95	RPM	1.02	1.03	1.09	1.01	1.02	1.06	1.01	1.01	1.03
	BHP	1.06	1.08	1.29	1.04	1.06	1.20	1.02	1.02	1.08
85	RPM	1.02	1.02	1.08	1.01	1.02	1.06	1.01	1.01	1.03
	BHP	1.05	1.07	1.26	1.03	1.05	1.18	1.02	1.02	1.08
75	RPM	1.01	1.02	1.07	1.01	1.02	1.05	1.00	1.01	1.02
	BHP	1.04	1.06	1.23	1.03	1.05	1.16	1.01	1.02	1.07
65	RPM	1.01	1.02	1.06	1.01	1.01	1.04	1.00	1.01	1.02
	BHP	1.04	1.06	1.19	1.03	1.04	1.14	1.01	1.02	1.06
55	RPM	1.01	1.02	1.05	1.01	1.01	1.04	1.00	1.01	1.02
	BHP	1.03	1.05	1.16	1.02	1.03	1.12	1.01	1.02	1.05
45	RPM	1.01	1.01	1.04	1.01	1.01	1.03	1.00	1.00	1.01
	BHP	1.02	1.04	1.13	1.02	1.03	1.09	1.01	1.01	1.04

Table 6. WOV Factors

SIZE	WOV FACTOR	D
121	1.08	12.40
141	1.55	13.98
161	2.22	15.75
181	3.42	17.72
201	4.68	19.68
221	6.58	22.05
251	9.37	24.80
281	14.31	27.95
321	20.47	31.50
351	31.51	35.43
391	43.24	39.37
441	60.73	44.09
491	84.44	49.21

Table 7. Temperature and Altitude Correction Factors

AIR TEMP °F	ALTITUDE IN FEET ABOVE SEA LEVEL											
	0	1000	2000	3000	4000	5000	6000	7000	8000	9000	10000	15000
	BAROMETRIC PRESSURE IN INCHES OF MERCURY											
	29.92	28.86	27.82	26.82	25.84	24.90	23.98	23.09	22.22	21.39	20.58	16.89
70	1.000	0.964	0.930	0.896	0.864	0.832	0.801	0.772	0.743	0.714	0.688	0.564
100	0.946	0.912	0.880	0.848	0.818	0.787	0.758	0.730	0.703	0.676	0.651	0.534
150	0.869	0.838	0.808	0.770	0.751	0.723	0.696	0.671	0.646	0.620	0.598	0.490
200	0.803	0.774	0.747	0.720	0.694	0.668	0.643	0.620	0.596	0.573	0.552	0.453
250	0.747	0.720	0.694	0.669	0.645	0.622	0.598	0.576	0.555	0.533	0.514	0.421
300	0.697	0.672	0.648	0.624	0.604	0.580	0.558	0.538	0.518	0.498	0.480	0.393
400	0.616	0.594	0.573	0.552	0.532	0.513	0.493	0.476	0.458	0.440	0.424	0.347
500	0.552	0.532	0.513	0.495	0.477	0.459	0.442	0.426	0.410	0.394	0.380	0.311
600	0.500	0.482	0.469	0.448	0.432	0.416	0.400	0.386	0.372	0.352	0.344	0.282
700	0.457	0.441	0.425	0.410	0.395	0.380	0.366	0.353	0.340	0.326	0.315	0.258
800	0.420	0.404	0.389	0.375	0.362	0.350	0.336	0.323	0.311	0.300	0.290	0.237
900	0.389	0.376	0.363	0.349	0.336	0.324	0.312	0.300	0.289	0.279	0.268	0.220
1000	0.363	0.350	0.338	0.325	0.314	0.302	0.291	0.280	0.270	0.259	0.250	0.205

Table 8. Derating Factors For High Temperature

TEMP. (°F)	STEEL			STAINLESS STEEL	
	CLASS II		CLASS III	CLASS II	CLASS III
	121-281	321-491			
70	1.00	1.00	1.00	1.00	1.00
200	0.99	0.97	0.97	1.00	0.98
250	0.98	0.96	0.96	1.00	0.96
300	0.97	0.95	0.95	1.00	0.94
400	0.96	0.93	0.93	1.00	0.91
500	0.93	0.90	0.90	0.97	0.87
600	0.90	0.87	0.87	0.94	0.84
700	0.88	0.84	0.84	0.90	0.80
800	0.83	0.81	0.81	0.87	0.78
1000	N/A	N/A	N/A	0.81	0.75

When operating fans at elevated temperatures, the maximum RPMs of the fan from Table 1 on page 5 must be corrected to the safe operating RPM limit for the application using the factors listed in the Table 8.

# Plug Fan Selection

The performance tables in this catalog are based on fans handling standard air at a density of 0.075 pounds per cubic foot. This is equivalent to air at 70°F at sea level (29.92 Hg barometric pressure). When specified performance is at a density different than standard, it must be converted to the equivalent standard conditions before the fan can be selected from the performance tables. The performance data and examples in this catalog are for unhooused BFPL plug fans.

$$\% \text{ WOV} = \frac{17000 \times 100}{1478 \times 15.19} = 75.7$$

## Example 1. Standard Density

**Given:** 17000 CFM at 3" TSP (system). Installation is a two-wall arrangement with a wheel-to-wall clearance of 7".

**Step 1.** Entering the performance tables we find that a 281 BFPL plug fan will deliver 17000 CFM at 3" SP operating at 1478 RPM with 11.33 BHP.

**Step 2.** Catalog performance must be corrected for wheel-to-wall arrangement. Determine the wheel and plenum type from the arrangements shown in Figure 1 on page 6. Determine the clearance "C" based upon the closest wall. Performance will not be affected by any additional walls spaced greater than C x 3 from the wheel.

The selected 281 BFPL fan has a wheel diameter of 27.95" ("D"). Application is two walls with 7" clearance ("C"). Therefore,  $C \div D = 7 \div 27.95 = 0.25$  or  $\frac{1}{4}$ " which is equivalent to  $D \div 4$ .

**Step 3.** Next, determine the Percent of Wide Open Volume (% WOV) at which the fan is to operate. From Table 6 on page 6 find that the WOV factor is 15.19 for a 281 BFPL fan.

**Step 4.** By interpolation from Table 5 on page 6, for the two wall column of  $D \div 4$  at 75.7% WOV, we find the RPM factor of 1.02 and the BHP factor of 1.05.

Corrected unhooused performance for 17000 CFM at 3" SP standard air is:

$$\begin{aligned} \text{RPM} &= 1478 \times 1.02 = 1508 \\ \text{BHP} &= 11.33 \times 1.05 = 11.90 \end{aligned}$$

## Example 2. Nonstandard Density

**Given:** 17000 CFM at 3" TSP (system), 300°F, 4000 ft. altitude. Installation is a two-wall arrangement with a wheel-to-wall clearance of 7".

**Step 1.** To enter the performance tables the operating SP must be corrected to equivalent standard conditions. From Table 7 on page 6 find the correction factor of 0.604 for 300°F and 4000 feet altitude. The corrected equivalent static pressure is equal to:

$$\text{SP (Catalog)} = \frac{3" \text{ TSP (system)}}{0.604} = 5.0$$

Fan selection is then made for 17000 CFM at 5" SP. Entering the performance tables, we find that a 281 BFPL fan will deliver 17000 CFM at 1638 RPM with 17.29 BHP. It must be remembered that this BHP is cataloged at standard 70°F air at sea level.

**Steps 2, 3, & 4.** Continue the correction procedure with Steps 2, 3 and 4 as shown in Example 1. Wall arrangement =  $D \div 4$ , % WOV = 60.0, RPM = 1654, and BHP = 17.90.

# Performance Data

## 121 BFPL

Wheel Dia.: 12.40" Max. BHP = 0.07 x (RPM ÷ 1000)<sup>3</sup>

CFM	0.5" SP		1" SP		1.5" SP		2" SP		2.5" SP		3" SP		3.5" SP		4" SP		4.5" SP		5" SP		5.5" SP		6" SP		
	RPM	BHP	RPM	BHP	RPM	BHP	RPM	BHP	RPM	BHP	RPM	BHP	RPM	BHP	RPM	BHP	RPM	BHP	RPM	BHP	RPM	BHP	RPM	BHP	
700	1155	0.09	1522	0.21																					
800	1201	0.10	1563	0.23	1842	0.36																			
900	1261	0.11	1602	0.24	1881	0.39	2119	0.55																	
1000	1327	0.13	1637	0.26	1923	0.42	2156	0.59	2367	0.77															
1200	1473	0.17	1738	0.30	1996	0.47	2239	0.66	2444	0.86	2631	1.07	2807	1.29	2972	1.51									
1400	1627	0.22	1868	0.35	2087	0.52	2309	0.72	2525	0.95	2713	1.18	2884	1.42	3044	1.66	3196	1.91	3343	2.16	3482	2.42			
1600	1784	0.29	2010	0.43	2211	0.60	2401	0.79	2595	1.02	2789	1.28	2966	1.54	3126	1.81	3275	2.08	3417	2.35	3553	2.63	3685	2.92	
1800	1945	0.38	2161	0.53	2346	0.70	2522	0.89	2691	1.11	2862	1.36	3037	1.64	3205	1.94	3358	2.24	3500	2.54	3634	2.84	3762	3.14	
2000	2109	0.48	2316	0.64	2492	0.82	2655	1.02	2812	1.24	2964	1.48	3116	1.75	3273	2.05	3430	2.37	3578	2.70	3716	3.03			
2200	2276	0.60	2473	0.78	2643	0.97	2796	1.17	2944	1.39	3086	1.64	3224	1.90	3362	2.19	3503	2.50	3647	2.84					
2400	2444	0.74	2633	0.93	2798	1.14	2945	1.35	3083	1.57	3218	1.82	3348	2.08	3476	2.37	3602	2.68	3729	3.00					
2600	2615	0.91	2795	1.12	2954	1.33	3098	1.55	3230	1.78	3356	2.03	3481	2.30	3602	2.59	3720	2.89							
2800	2787	1.09	2959	1.32	3113	1.55	3253	1.78	3382	2.03	3502	2.28	3619	2.55	3735	2.84									
3000	2960	1.31	3125	1.55	3273	1.79	3410	2.04	3536	2.30	3653	2.56	3765	2.84											
3200	3134	1.55	3293	1.81	3436	2.07	3568	2.33	3692	2.60															
3400	3310	1.83	3462	2.11	3600	2.38	3728	2.65																	
3600	3486	2.13	3632	2.43	3766	2.72																			
3800	3663	2.47																							
4000																									

Maximum RPM @ 70°F: Class II — 3778

Must derate for temperature and plug wall thickness.

Underlined figures indicate maximum static efficiency.

Power rating (BHP) does not include transmission losses.

# Performance Data

## 141 BFPL

Wheel Dia.: 13.98"

Max. BHP = 0.12 x (RPM ÷ 1000)<sup>3</sup>

CFM	0.5" SP		1" SP		1.5" SP		2" SP		2.5" SP		3" SP		3.5" SP		4" SP		4.5" SP		5" SP		5.5" SP		6" SP	
	RPM	BHP	RPM	BHP	RPM	BHP	RPM	BHP	RPM	BHP	RPM	BHP	RPM	BHP	RPM	BHP	RPM	BHP	RPM	BHP	RPM	BHP	RPM	BHP
900	1027	0.12	1353	0.27																				
1000	1058	0.12	1381	0.28	1630	0.46																		
1200	1144	0.15	1434	0.32	1685	0.52	1894	0.72	2083	0.94														
1400	1241	0.19	<u>1492</u>	<u>0.35</u>	1740	0.57	1950	0.80	2132	1.04	2302	1.29												
1600	1346	0.23	<u>1574</u>	<u>0.40</u>	1790	0.61	2005	0.87	2190	1.13	2355	1.40	2508	1.68	2654	1.97								
1800	1454	0.29	1666	0.46	<u>1860</u>	<u>0.67</u>	2054	0.92	2245	1.22	2413	1.51	2564	1.81	2705	2.12	2840	2.44	2970	2.77	3094	3.10		
2000	1564	0.36	1765	0.53	<u>1946</u>	<u>0.75</u>	2117	0.99	2293	1.28	2466	1.61	2622	1.94	2763	2.27	2895	2.61	3021	2.95	3143	3.31	3260	3.67
2200	1675	0.44	1870	0.63	2039	0.84	<u>2198</u>	<u>1.09</u>	2354	1.37	2514	1.69	2673	2.05	2820	2.41	2953	2.77	3079	3.14	3198	3.52	3312	3.89
2400	1789	0.53	1977	0.73	2137	0.95	2288	1.20	<u>2432</u>	<u>1.48</u>	2575	1.79	2722	2.14	2869	2.53	3008	2.93	3136	3.32	3256	3.72		
2600	1904	0.64	2086	0.85	2240	1.08	2383	1.33	<u>2520</u>	<u>1.62</u>	2652	1.93	<u>2784</u>	<u>2.27</u>	2919	2.64	3056	3.05	3188	3.48	3312	3.91		
2800	2021	0.76	2196	0.99	2347	1.23	2482	1.49	2613	1.77	<u>2739</u>	<u>2.08</u>	<u>2861</u>	<u>2.42</u>	<u>2983</u>	<u>2.78</u>	3108	3.18	3235	3.61				
3000	2138	0.90	2307	1.15	2455	1.40	2586	1.66	2709	1.95	2831	2.26	<u>2947</u>	<u>2.60</u>	<u>3062</u>	<u>2.97</u>	3175	3.35	3291	3.77				
3200	2257	1.06	2420	1.32	2563	1.58	2692	1.86	2811	2.15	2926	2.47	3039	2.81	<u>3148</u>	<u>3.17</u>	<u>3255</u>	<u>3.56</u>						
3400	2376	1.24	2534	1.51	2673	1.79	2800	2.08	2915	2.38	3025	2.70	3133	3.04	3239	3.40	<u>3341</u>	<u>3.79</u>						
3800	2617	1.65	2764	1.96	2896	2.26	3017	2.58	3129	2.90	3233	3.24	3333	3.59										
4200	2861	2.15	2999	2.49	3123	2.83	3239	3.17	3347	3.52														
4600	3107	2.75	3236	3.13																				
5000																								
5400																								

Maximum RPM @ 70°F:

Class II — 3352

Must derate for temperature and plug wall thickness.

## 161 BFPL

Wheel Dia.: 15.75"

Max. BHP = 0.23 x (RPM ÷ 1000)<sup>3</sup>

CFM	0.5" SP		1" SP		1.5" SP		2" SP		2.5" SP		3" SP		3.5" SP		4" SP		4.5" SP		5" SP		5.5" SP		6" SP	
	RPM	BHP	RPM	BHP	RPM	BHP	RPM	BHP	RPM	BHP	RPM	BHP	RPM	BHP	RPM	BHP	RPM	BHP	RPM	BHP	RPM	BHP	RPM	BHP
1200	923	0.15	1212	0.35	1435	0.56																		
1400	977	0.17	1252	0.38	1471	0.62	1660	0.87																
1600	1041	0.20	1286	0.41	1511	0.67	1695	0.95	1861	1.23														
1800	1110	0.24	<u>1330</u>	<u>0.45</u>	1549	0.72	1735	1.02	1897	1.33	2047	1.65	2187	1.98										
2000	1183	0.29	<u>1387</u>	<u>0.49</u>	1583	0.77	1775	1.09	1937	1.42	2084	1.76	2221	2.12	2351	2.48								
2200	1258	0.34	1451	0.55	<u>1628</u>	<u>0.82</u>	1808	1.15	1977	1.51	2124	1.87	2259	2.25	2385	2.63	2506	3.03	2622	3.43				
2400	1335	0.41	1518	0.62	<u>1684</u>	<u>0.89</u>	1846	1.21	2012	1.58	2164	1.98	2299	2.38	2424	2.78	2543	3.20	2656	3.62	2766	4.06	2870	4.50
2600	1412	0.48	1589	0.70	1747	0.97	<u>1896</u>	<u>1.29</u>	2047	1.65	2199	2.07	2339	2.50	2465	2.93	2582	3.36	2694	3.81	2801	4.27	2904	4.73
2800	1490	0.56	1663	0.80	1812	1.07	1953	1.38	2091	1.74	2233	2.15	2374	2.61	2504	3.07	2623	3.53	2734	3.99	2840	4.47	2941	4.95
3000	1570	0.65	1738	0.90	1880	1.18	2016	1.50	<u>2145</u>	<u>1.85</u>	2274	2.25	2407	2.70	2539	3.19	2662	3.68	2775	4.18	2881	4.68		
3400	1731	0.87	1890	1.15	2025	1.44	2149	1.77	2269	2.13	<u>2384</u>	<u>2.52</u>	<u>2497</u>	<u>2.95</u>	2611	3.41	2729	3.93	2846	4.48	2957	5.04		
3800	1895	1.14	2045	1.45	2176	1.77	2292	2.10	2402	2.47	2510	2.86	2614	3.30	2715	3.75	2817	4.25	2919	4.77				
4200	2061	1.47	2203	1.81	2328	2.15	2441	2.51	2545	2.89	2644	3.28	2742	3.72	<u>2837</u>	<u>4.18</u>	<u>2930</u>	<u>4.67</u>						
4600	2229	1.85	2363	2.22	2483	2.59	2593	2.98	2694	3.38	2788	3.79	2878	4.22	2968	4.69								
5000	2398	2.30	2526	2.71	2641	3.11	2746	3.52	2845	3.95	2936	4.38												
5400	2569	2.82	2690	3.27	2800	3.70	2902	4.14																
5800	2741	3.42	2856	3.90	2962	4.38																		
6200	2914	4.11																						
6600																								

Maximum RPM @ 70°F:

Class II — 2975

Must derate for temperature and plug wall thickness.

## 181 BFPL

Wheel Dia.: 17.72"

Max. BHP = 0.41 x (RPM ÷ 1000)<sup>3</sup>

CFM	1" SP		2" SP		3" SP		4" SP		5" SP		6" SP		7" SP		8" SP		9" SP		10" SP		11" SP		12" SP	
	RPM	BHP	RPM	BHP	RPM	BHP	RPM	BHP	RPM	BHP	RPM	BHP	RPM	BHP	RPM	BHP	RPM	BHP	RPM	BHP	RPM	BHP	RPM	BHP
2000	1045	0.46																						
2500	1121	0.57																						
3000	1219	0.70	1498	1.36																				
3500	1327	0.84	<u>1578</u>	<u>1.58</u>	1814	2.42																		
4000	1441	1.03	1674	1.84	<u>1883</u>	<u>2.70</u>	2091	3.70																
4500	1561	1.26	1778	2.11	1973	3.07	2155	4.05	2340	5.19														
5000	1684	1.54	1888	2.42	2071	3.46	2241	4.52	2405	5.63	2572	6.89	2738	8.26										
5500	1811	1.86	2002	2.78	2175	3.87	2337	5.04	<u>2489</u>	<u>6.20</u>	<u>2638</u>	<u>7.43</u>	2789	8.79	2941	10.27								
6000	1941	2.22	2120	3.21	2284	4.32	2437	5.57	2583	6.84	2722	8.11	2859	9.45	2997	10.91	3136	12.48	3275	14.15				
6500	2074	2.62	2240	3.71	2398	4.84	2543	6.13	2682	7.51	2816	8.88	2944	10.26	3070	11.70	3197	13.24	3325	14.89	3454	16.65		
7000	2209	3.08	2364	4.27	2514	5.43	2654	6.75	2786	8.19	2914	9.68	3037	11.15	3156	12.63	3273	14.16	3391	15.79	3509	17.51		
7500	2345	3.59	2490	4.89	2632	6.12	2767	7.43	2894	8.91	3017	10.49												

# Performance Data

## 201 BFPL

Wheel Dia.: 19.68" Max. BHP = 0.68 x (RPM ÷ 1000)<sup>3</sup>

CFM	1" SP		2" SP		3" SP		4" SP		5" SP		6" SP		7" SP		8" SP		9" SP		10" SP		11" SP		12" SP	
	RPM	BHP	RPM	BHP	RPM	BHP	RPM	BHP	RPM	BHP	RPM	BHP	RPM	BHP	RPM	BHP	RPM	BHP	RPM	BHP	RPM	BHP	RPM	BHP
2500	944	0.58																						
3000	998	0.68																						
3500	1068	0.81	1332	1.62																				
4000	1144	0.94	1381	1.80	1612	2.85																		
4500	1225	1.10	1446	2.04	1649	3.07																		
5000	1309	1.29	1517	2.31	1704	3.38	1888	4.60																
5500	1396	1.53	1593	2.58	1769	3.74	1935	4.96	2103	6.36														
6000	1486	1.80	1672	2.87	1840	4.14	1996	5.41	2148	6.78	2302	8.34												
6500	1578	2.11	1755	3.21	1914	4.54	2064	5.92	2205	7.31	2346	8.84	2488	10.53	2630	12.35								
7000	1671	2.44	1839	3.60	1992	4.96	2135	6.44	2270	7.92	2401	9.45	2531	11.10	2664	12.93	2796	14.87						
7500	1767	2.81	1926	4.06	2073	5.43	2210	6.99	2340	8.57	2464	10.15	2586	11.81	2708	13.59	2832	15.54	2955	17.58				
8000	1864	3.22	2014	4.56	2156	5.95	2287	7.54	2413	9.24	2533	10.93	2648	12.62	2762	14.39	2877	16.30	2992	18.33	3108	20.49		
8500	1962	3.67	2104	5.11	2240	6.53	2368	8.15	2488	9.92	2604	11.72	2716	13.51	2824	15.32	2931	17.20	3039	19.21	3148	21.35		
9000	2061	4.16	2195	5.71	2326	7.19	2450	8.82	2566	10.62	2678	12.52	2787	14.44	2892	16.34	2994	18.26	3095	20.25	3196	22.34		
10000	2261	5.30	2383	7.05	2503	8.71	2619	10.37	2729	12.21	2833	14.21	2935	16.32	3034	18.44	3131	20.56						
11000	2464	6.65	2575	8.57	2685	10.46	2792	12.24	2897	14.11	2997	16.15	3092	18.33	3185	20.61								
12000	2668	8.23	2771	10.34	2872	12.43	2971	14.41	3070	16.38	3165	18.42												
13000	2874	10.07	2969	12.35	3063	14.63	3155	16.84																
14000	3081	12.18	3169	14.64																				

Maximum RPM @ 70°F:

Class II — 2380

Class III — 3202

Must derate for temperature and plug wall thickness.

## 221 BFPL

Wheel Dia.: 22.05" Max. BHP = 1.21 x (RPM ÷ 1000)<sup>3</sup>

CFM	1" SP		2" SP		3" SP		4" SP		5" SP		6" SP		7" SP		8" SP		9" SP		10" SP		11" SP		12" SP	
	RPM	BHP	RPM	BHP	RPM	BHP	RPM	BHP	RPM	BHP	RPM	BHP	RPM	BHP	RPM	BHP	RPM	BHP	RPM	BHP	RPM	BHP	RPM	BHP
3000	835	0.70																						
3500	867	0.79																						
4000	913	0.91																						
4500	964	1.04	1195	2.06																				
5000	1018	1.18	1231	2.25	1438	3.56																		
5500	1076	1.33	1276	2.49	1463	3.78																		
6000	1135	1.51	1326	2.75	1497	4.05	1670	5.61																
7000	1258	1.97	1432	3.29	1588	4.77	1735	6.30	1883	8.06														
8000	1387	2.54	1547	3.92	1691	5.57	1826	7.26	1954	9.00	2083	10.93	2213	13.06	2390	16.50	2505	18.93						
9000	1521	3.22	1668	4.71	1802	6.42	1928	8.32	2047	10.22	2161	12.15	2275	14.23	2462	18.00	2564	20.37	2668	22.94	2772	25.66		
10000	1658	4.00	1792	5.68	1919	7.42	2037	9.43	2149	11.55	2256	13.64	2360	15.78	2462	18.00	2564	20.37	2668	22.94	2772	25.66		
11000	1797	4.92	1920	6.80	2040	8.62	2151	10.65	2257	12.91	2359	15.25	2457	17.57	2552	19.89	2645	22.28	2737	24.75	2831	27.43		
12000	1939	5.99	2052	8.07	2164	10.05	2270	12.10	2371	14.42	2467	16.89	2560	19.43	2651	21.97	2739	24.50	2825	27.06				
13000	2082	7.22	2187	9.49	2291	11.67	2392	13.81	2488	16.12	2580	18.66	2669	21.36	2755	24.11	2840	26.88						
14000	2227	8.63	2325	11.09	2421	13.48	2516	15.76	2609	18.12	2697	20.67	2782	23.43										
15000	2372	10.22	2464	12.86	2554	15.46	2644	17.95	2732	20.40	2817	22.96												
16000	2518	12.02	2605	14.84	2690	17.63	2774	20.34	2857	22.94														
17000	2665	14.03	2747	17.03	2827	19.99																		
18000	2812	16.27																						

Maximum RPM @ 70°F:

Class II — 2125

Class III — 2859

Must derate for temperature and plug wall thickness.

## 251 BFPL

Wheel Dia.: 24.80" Max. BHP = 2.17 x (RPM ÷ 1000)<sup>3</sup>

CFM	1" SP		2" SP		3" SP		4" SP		5" SP		6" SP		7" SP		8" SP		9" SP		10" SP		11" SP		12" SP	
	RPM	BHP	RPM	BHP	RPM	BHP	RPM	BHP	RPM	BHP	RPM	BHP	RPM	BHP	RPM	BHP	RPM	BHP	RPM	BHP	RPM	BHP	RPM	BHP
4000	750	0.92																						
5000	808	1.13																						
6000	880	1.40	1077	2.72																				
7000	960	1.70	1137	3.16	1302	4.80																		
8000	1044	2.08	1208	3.69	1356	5.40	1500	7.34																
9000	1132	2.57	1285	4.25	1423	6.16	1551	8.10	1680	10.31	1809	12.78												
10000	1222	3.14	1366	4.88	1495	6.95	1615	9.05	1730	11.24	1846	13.68	1963	16.39										
11000	1315	3.79	1450	5.63	1572	7.78	1686	10.11	1794	12.44	1898	14.84	2003	17.48	2110	20.40	2215	23.46						
12000	1411	4.53	1536	6.53	1652	8.70	1760	11.18	1864	13.75	1962	16.28	2057	18.89	2153	21.71	2251	24.80	2348	28.05				
13000	1508	5.37	1625	7.57	1736	9.78	1839	12.34	1937	15.08	2031	17.82	2121	20.56	2210	23.40	2298	26.38	2388	29.63	2478	33.06		
14000	1607	6.32	1715	8.71	1821	11.02	1920	13.60	2013	16.44	2103	19.41	2191	22.39	2275	25.34	2357	28.36	2439	31.52	2521	34.85		
15000	1706	7.38	1808	9.98	1908	12.44	2003	15.02	2093	17.94	2179	21.05	2263	24.25	2344	27.40	2423	30.58	2500	33.79				
16000	1806	8.56	1902	11.35	1997	14.02	2088	16.66	2175	19.59	2258	22.79	2338	26.13	2417	29.56	2493	32.93						
17000	1908	9.90	1998	12.86	2087	15.73	2175	18.52	2259	21.45	2339	24.68	2417	28.15	2492	31.72								
18000	2009	11.35	2095	14.51																				

# Performance Data

## 281 BFPL

Wheel Dia.: 27.95"

Max. BHP = 4.26 x (RPM ÷ 1000)<sup>3</sup>

CFM	1" SP		2" SP		3" SP		4" SP		5" SP		6" SP		7" SP		8" SP		9" SP		10" SP		11" SP		12" SP	
	RPM	BHP	RPM	BHP	RPM	BHP	RPM	BHP	RPM	BHP	RPM	BHP	RPM	BHP	RPM	BHP	RPM	BHP	RPM	BHP	RPM	BHP	RPM	BHP
6000	664	1.24																						
7000	<u>704</u>	<u>1.42</u>																						
8000	753	1.64																						
9000	807	1.92	958	3.67																				
10000	864	2.25	1000	<u>4.04</u>	1138	6.27																		
11000	925	2.64	1049	4.50	1172	6.73																		
12000	987	3.10	1101	5.00	<u>1214</u>	<u>7.29</u>	1328	9.92																
13000	1051	3.62	1157	5.60	<u>1261</u>	<u>7.93</u>	<u>1365</u>	<u>10.57</u>	1472	13.57														
14000	1115	4.21	1214	6.26	1311	8.64	<u>1408</u>	<u>11.33</u>	1505	14.30	1606	17.65												
15000	1179	4.85	1274	7.02	1365	9.45	<u>1455</u>	<u>12.19</u>	<u>1546</u>	<u>15.21</u>	1637	18.50	1732	22.15										
16000	1243	5.56	1335	7.85	1421	10.35	1506	13.15	<u>1590</u>	<u>16.19</u>	<u>1675</u>	<u>19.50</u>	1761	23.09										
17000	1308	6.36	1398	8.79	1478	11.33	1559	14.20	<u>1638</u>	<u>17.29</u>	<u>1718</u>	<u>20.64</u>	<u>1798</u>	<u>24.23</u>	1879	28.08	1964	32.29						
18000	1373	7.23	1461	9.81	1537	12.43	1614	15.35	1689	18.50	<u>1764</u>	<u>21.89</u>	<u>1840</u>	<u>25.52</u>	1916	29.39	1992	33.46	2072	37.91				
19000	1438	8.18	1525	10.93	1598	13.65	1671	16.62	1742	19.81	1813	23.25	<u>1885</u>	<u>26.94</u>	<u>1957</u>	<u>30.83</u>	2028	34.90	2101	39.25	2176	43.89		
20000	1504	9.23	1589	12.13	1660	14.97	1728	17.97	1798	21.28	1865	24.75	<u>1933</u>	<u>28.49</u>	<u>2001</u>	<u>32.41</u>	<u>2069</u>	<u>36.52</u>	2137	40.84	2206	45.41		
21000	1570	10.37	1653	13.42	1723	16.41	1788	19.48	1854	22.82	1919	26.38	1983	30.13	<u>2047</u>	<u>34.07</u>	<u>2113</u>	<u>38.29</u>	<u>2177</u>	<u>42.59</u>	2242	47.15		
22000	1636	11.60	1718	14.83	1787	17.97	1849	21.12	1911	24.47	1974	28.10	2036	31.94	2097	35.94	<u>2159</u>	<u>40.17</u>	<u>2221</u>	<u>44.56</u>				
24000	1769	14.39	1847	17.91	1914	21.36	1974	24.78	2031	28.28	2088	31.98	2146	35.95	2202	40.04								
26000	1903	17.63	1977	21.45	2043	25.24	2101	28.94	2155	32.66	2207	36.46												

Maximum RPM @ 70°F:

Class II — 1676

Class III — 2255

Must derate for temperature and plug wall thickness.

## 321 BFPL

Wheel Dia.: 31.50"

Max. BHP = 7.75 x (RPM ÷ 1000)<sup>3</sup>

CFM	1" SP		2" SP		3" SP		4" SP		5" SP		6" SP		7" SP		8" SP		9" SP		10" SP		11" SP		12" SP	
	RPM	BHP	RPM	BHP	RPM	BHP	RPM	BHP	RPM	BHP	RPM	BHP	RPM	BHP	RPM	BHP	RPM	BHP	RPM	BHP	RPM	BHP	RPM	BHP
8000	599	1.63																						
9000	629	<u>1.83</u>																						
10000	663	2.05																						
11000	700	2.31	839	4.52																				
12000	739	2.62	<u>867</u>	<u>4.87</u>																				
13000	780	2.97	<u>898</u>	<u>5.27</u>	1017	8.10																		
14000	822	3.36	932	5.72	<u>1041</u>	<u>8.56</u>																		
15000	866	3.82	969	6.24	<u>1070</u>	<u>9.10</u>	1174	12.47																
16000	910	4.32	1007	6.80	<u>1102</u>	<u>9.73</u>	1198	13.07																
17000	955	4.88	1046	7.41	1136	10.40	<u>1226</u>	<u>13.78</u>	1317	17.56														
18000	1000	5.48	1087	8.11	1172	11.14	<u>1257</u>	<u>14.57</u>	1342	18.35	1430	22.59												
20000	1090	6.85	1172	9.71	1249	12.85	1325	16.37	<u>1402</u>	<u>20.26</u>	1478	24.42	1556	28.99										
22000	1180	8.42	1259	11.57	1329	14.83	1400	18.50	1469	22.46	<u>1538</u>	<u>26.71</u>	<u>1608</u>	<u>31.29</u>	1678	36.16	1750	41.41						
24000	1271	10.26	1348	13.73	1414	17.20	1478	20.92	1542	25.00	1605	29.35	<u>1669</u>	<u>34.01</u>	<u>1733</u>	<u>38.93</u>	1797	44.13	1862	49.64	1929	55.52		
26000	1363	12.39	1438	16.18	1501	19.89	1560	23.75	1619	27.90	1678	32.38	1737	37.15	<u>1796</u>	<u>42.18</u>	<u>1855</u>	<u>47.42</u>	<u>1914</u>	<u>52.93</u>	1973	58.68		
28000	1456	14.84	<u>1528</u>	<u>18.92</u>	1589	22.91	1645	26.96	1699	31.19	1755	35.81	1810	40.69	1864	45.77	<u>1918</u>	<u>51.08</u>	<u>1973</u>	<u>56.66</u>				
30000	1549	17.59	1618	21.97	1678	26.27	1732	30.57	1783	34.97	1834	39.61	1886	44.61	1937	49.82	1988	55.28						
32000	1642	20.68	1709	25.38	1768	30.02	1820	34.56	1869	39.18	1917	43.97	1965	49.00										
34000	1736	24.17	1801	29.19	1858	34.12	1909	38.96	1956	43.79														

Maximum RPM @ 70°F:

Class II — 1487

Class III — 2001

Must derate for temperature and plug wall thickness.

## 351 BFPL

Wheel Dia.: 35.43"

Max. BHP = 14.21 x (RPM ÷ 1000)<sup>3</sup>

CFM	1" SP		2" SP		3" SP		4" SP		5" SP		6" SP		7" SP		8" SP		9" SP		10" SP		11" SP		12" SP	
	RPM	BHP	RPM	BHP	RPM	BHP	RPM	BHP	RPM	BHP	RPM	BHP	RPM	BHP	RPM	BHP	RPM	BHP	RPM	BHP	RPM	BHP	RPM	BHP
9000	507	1.85																						
10000	521	<u>2.00</u>																						
12000	559	2.44	709	5.06																				
14000	609	2.94	<u>735</u>	<u>5.61</u>																				
16000	666	3.54	770	6.44	883	9.76																		
18000	724	4.23	814	7.39	914	<u>10.79</u>	1014	14.80																
20000	779	5.00	867	8.44	951	12.10	<u>1042</u>	<u>15.99</u>	1132	20.60														
22000	834	5.92	923	9.59	995	13.51	<u>1076</u>	<u>17.60</u>	<u>1159</u>	<u>22.01</u>	1241	27.14	1322	32.77										
24000	888	6.93	981	10.89	1048	15.10	1117	19.47	<u>1193</u>	<u>24.00</u>	1269	28.89	1343	34.38	1417	40.40								
26000	943	8.08	1039	12.36	1104	16.79	1164	21.41	1231	26.22	<u>1301</u>	<u>31.12</u>	<u>1371</u>	<u>36.43</u>	1440	42.36	1509	48.81						
28000	999	9.36	1094	13.92	1162	18.66	1218	23.55	1276	28.66	1339	33.82	<u>1404</u>	<u>39.12</u>	<u>1469</u>	<u>44.81</u>	1533	51.07	1597	57.57	1654	63.94	1710	70.75
30000	1056	10.77	1149	15.68	1219	20.65	1274	25.81	1326	31.15	1382	36.67	1441	42.19	<u>1502</u>	<u>47.89</u>	<u>1563</u>	<u>53.96</u>	1623	60.55	1683	67.67	1742	75.10
32000	1114																							

# Performance Data

## 391 BFPL

Wheel Dia.: 39.37"

Max. BHP = 24.08 x (RPM ÷ 1000)<sup>3</sup>

CFM	1" SP		2" SP		3" SP		4" SP		5" SP		6" SP		7" SP		8" SP		9" SP		10" SP		11" SP		12" SP	
	RPM	BHP	RPM	BHP	RPM	BHP	RPM	BHP	RPM	BHP	RPM	BHP	RPM	BHP	RPM	BHP	RPM	BHP	RPM	BHP	RPM	BHP	RPM	BHP
12000	465	2.41																						
14000	490	2.81																						
16000	523	3.30	648	6.54																				
18000	562	3.82	670	7.20	780	11.41																		
20000	604	4.44	696	8.05	797	12.16																		
22000	646	5.12	728	9.00	819	13.15	910	18.13																
24000	687	5.89	766	10.04	846	14.48	930	19.28	1013	25.02														
26000	727	6.75	807	11.17	876	15.86	954	20.79	1031	26.31	1107	32.65												
28000	767	7.72	849	12.40	911	17.33	980	22.48	1053	27.95	1124	34.12	1195	41.07										
30000	806	8.75	891	13.73	950	18.91	1011	24.38	1078	29.99	1146	36.04	1212	42.79	1278	50.23								
32000	846	9.90	933	15.19	991	20.62	1046	26.37	1106	32.23	1170	38.35	1233	44.91	1295	52.20	1357	60.14						
34000	887	11.16	973	16.72	1033	22.46	1084	28.41	1138	34.64	1197	41.00	1257	47.55	1316	54.61	1374	62.35	1433	70.83	1490	79.48		
36000	928	12.52	1013	18.41	1075	24.41	1125	30.67	1173	37.07	1227	43.80	1282	50.42	1339	57.48	1395	65.06	1450	73.26	1505	82.04	1560	91.30
38000	970	14.00	1053	20.26	1118	26.59	1167	33.06	1212	39.72	1260	46.69	1311	53.65	1364	60.76	1418	68.26	1471	76.28	1523	84.86	1575	94.01
40000	1012	15.59	1092	22.19	1159	28.81	1209	35.57	1252	42.43	1296	49.65	1343	57.03	1392	64.36	1443	71.95	1494	79.83	1544	88.19	1594	97.25
42000	1055	17.35	1132	24.32	1199	31.16	1251	38.23	1294	45.41	1335	52.80	1377	60.37	1423	68.16	1471	76.03	1519	83.93	1568	92.29		
44000	1098	19.23	1172	26.57	1239	33.71	1293	41.06	1336	48.50	1376	56.18	1415	63.99	1457	72.12	1501	80.22	1546	88.31	1593	96.80		
46000	1141	21.25	1212	28.94	1279	36.46	1334	44.02	1378	51.75	1417	59.64	1455	67.79	1493	76.06	1534	84.60	1576	93.01				
48000	1184	23.41	1253	31.49	1318	39.29	1375	47.21	1421	55.29	1459	63.34	1496	71.75	1532	80.28	1569	88.99						

Maximum RPM @ 70°F:

Class II — 1190

Class III — 1601

Must derate for temperature and plug wall thickness.

## 441 BFPL

Wheel Dia.: 44.09"

Max. BHP = 42.41 x (RPM ÷ 1000)<sup>3</sup>

CFM	1" SP		2" SP		3" SP		4" SP		5" SP		6" SP		7" SP		8" SP		9" SP		10" SP		11" SP		12" SP	
	RPM	BHP	RPM	BHP	RPM	BHP	RPM	BHP	RPM	BHP	RPM	BHP	RPM	BHP	RPM	BHP	RPM	BHP	RPM	BHP	RPM	BHP	RPM	BHP
14000	408	2.88																						
16000	423	3.19																						
18000	442	3.62																						
20000	466	4.11	578	8.18																				
22000	494	4.65	593	8.79																				
24000	523	5.22	611	9.62	704	14.79																		
26000	553	5.86	632	10.55	719	15.69	804	22.01																
28000	583	6.58	655	11.47	735	16.75	815	22.93																
30000	612	7.34	682	12.50	754	18.06	830	24.14	904	31.32														
32000	641	8.21	711	13.62	775	19.43	846	25.54	916	32.53	985	40.49												
34000	669	9.12	741	14.82	799	20.90	864	27.19	931	34.05	997	42.00	1062	50.69										
36000	697	10.11	771	16.10	825	22.38	885	29.08	948	35.93	1010	43.55	1072	52.23										
38000	725	11.18	801	17.46	854	24.05	907	30.92	966	38.01	1026	45.55	1085	54.05	1143	63.31								
40000	754	12.36	831	18.94	883	25.74	932	32.90	987	40.37	1043	47.86	1100	56.17	1156	65.42	1211	75.29						
44000	812	14.91	889	22.15	943	29.50	988	37.18	1033	45.12	1083	53.30	1134	61.51	1186	70.35	1237	80.01	1287	90.33	1338	101.53		
48000	871	17.80	945	25.72	1003	33.68	1047	41.87	1087	50.26	1129	59.01	1175	67.96	1222	76.94	1269	86.18	1316	96.17	1363	107.11	1409	118.54
52000	932	21.17	1001	29.75	1061	38.26	1107	47.03	1145	55.88	1183	65.21	1221	74.55	1263	84.20	1306	93.82	1350	103.78	1394	114.23		
56000	993	24.93	1058	34.26	1118	43.37	1167	52.74	1205	62.10	1241	71.93	1275	81.78	1311	92.00	1349	102.24	1389	112.66				
60000	1055	29.20	1116	39.24	1175	49.10	1225	58.90	1265	68.84	1300	79.09	1333	89.60	1365	100.22	1398	111.05						

Maximum RPM @ 70°F:

Class II — 1062

Class III — 1429

Must derate for temperature and plug wall thickness.

## 491 BFPL

Wheel Dia.: 49.21"

Max. BHP = 73.45 x (RPM ÷ 1000)<sup>3</sup>

CFM	1" SP		2" SP		3" SP		4" SP		5" SP		6" SP		7" SP		8" SP		9" SP		10" SP		11" SP		12" SP	
	RPM	BHP	RPM	BHP	RPM	BHP	RPM	BHP	RPM	BHP	RPM	BHP	RPM	BHP	RPM	BHP	RPM	BHP	RPM	BHP	RPM	BHP	RPM	BHP
16000	359	3.39																						
18000	368	3.65																						
20000	379	3.98																						
22000	393	4.42																						
24000	409	4.89	514	9.97																				
26000	428	5.40	523	10.47																				
28000	449	5.96	535	11.19	624	17.82																		
32000	492	7.21	563	12.95	642	19.36	719	27.24																
36000	534	8.61	598	14.90	666	21.58	736	29.21	805	38.26														
40000	576	10.30	639	17.08	696	24.36	759	31.94	822	40.71	883	50.53												
44000	616	12.17	682	19.54	731	27.24	786	35.37	844	43.91	901	53.60	957	64.36										
48000	657	14.34	725	22.25	772	30.51	819	39.26	870	48.06	923	57.43	975	67.88	1027	79.54	1078	91.82						
52000	698	16.73	767	25.23	815	34.11	856	43.20	901	52.76	949	62.41	998	72.60	1046	83.76	1094	96.10	1142	109.33				
56000	740	19.39	808	28.55	858	37.97	897	47.56	936	57.59	979	67.94	1024	78.41	1070	89.48	1115	101.38	1159	114.17				
60000	783	22.37	849	32.27	901	42.20	940	52.36	976	62.89	1013	73.72	1054	84.92	1096	96.14	1138	107.66	1180	120.07				
64000	826	25.64	889	36.24	943	46.79	983	57.47	1018	68.55	1052	79.98	1087	91.53	1126	103.58	1165	115.43						
68000	870	29.31	930	40.65	984	51.75	1026	62.99	1061	74.64	1093	86.50	1125	98.69	1159	111.19	1195	123.77						
72000	914	33.31	971	45.37	1025	57.21	1069	69.04	1104	81.09	1135	93.40	1165	106.05	1196	119.18								
76000	959	37.79	1013	50.52	1065	62.96	1110	75.33	1147	88.02	1178	100.85	1207	114.00										

Maximum RPM @ 70°F:

Class II — 952

Class III — 1281

Must derate for temperature and plug wall thickness.

Underlined figures indicate maximum static efficiency.

Power rating (BHP) does not include transmission losses.

# Dimensional Data – Class I I

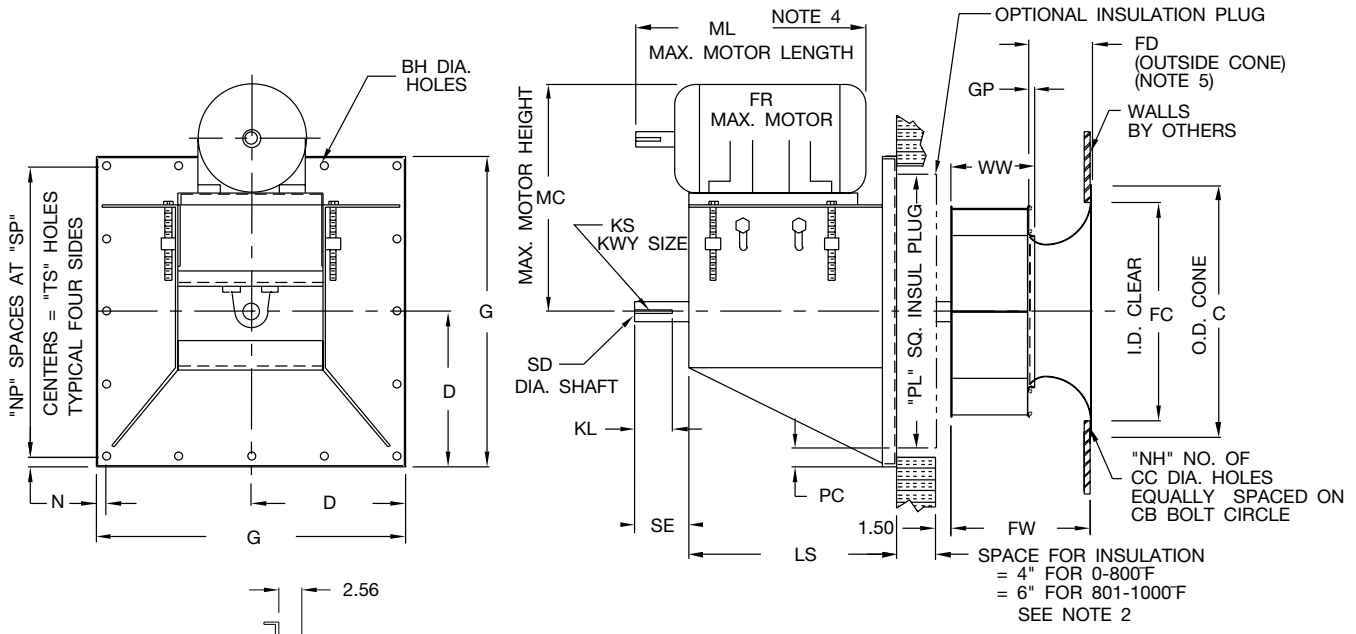

**NOTES:**

1. Dimensions apply to unboxed assembly only.
2. When specified, the shaft length can be extended an additional 2 inches for 6 inches of insulation, for operation to 800°F, without changes to the shaft diameter. See Detail "A" for shaft cooler recess cone and shaft seal on fans over 300°F with 4 inches or larger insulation plug.
3. CW rotation is standard. CCW rotation is optional.
4. To insure selected motor will fit standard assembly, compare the maximum motor length, dimension "ML," to overall motor length.
5. Dimensions are subject to change based on accessories. See page 14 for accessory options.
6. Dimensions shown are in inches unless otherwise indicated.

SIZE	BH	C	CB	CC	D	FC	FD	FW	G	GP	KL	KS	LS
121	0.56	17.13	15.88	0.69	11.38	13.75	3.72	8.48	22.75	0.25	4.00	.38x.19	17.50
141	0.56	18.91	17.63	0.69	11.38	15.50	4.19	9.55	22.75	0.25	4.00	.38x.19	18.50
161	0.56	20.88	19.59	0.88	14.81	17.75	4.72	10.75	29.63	0.25	4.00	.38x.19	18.50
181	0.56	22.84	21.56	0.88	14.81	20.00	5.31	12.16	29.63	0.31	4.50	.50x.25	21.00
201	0.56	25.19	23.94	0.88	14.81	22.00	5.88	13.39	29.63	0.31	4.50	.50x.25	21.00
221	0.56	27.97	26.69	0.88	16.00	24.50	6.59	15.01	32.00	0.31	4.50	.50x.25	22.50
251	0.56	31.13	29.84	1.00	16.00	27.50	7.44	16.93	32.00	0.50	4.50	.50x.25	22.50
281	0.69	34.66	33.38	1.00	18.31	30.75	8.38	19.06	36.63	0.50	5.00	.50x.25	23.00
321	0.69	39.59	37.84	1.00	21.81	35.00	9.44	21.40	43.63	0.56	5.00	.50x.25	24.50
351	0.69	43.53	41.78	1.00	21.81	39.25	10.63	24.08	43.63	0.63	5.50	.63x.31	24.50
391	0.69	48.31	46.53	1.00	27.50	43.50	11.75	26.77	55.00	0.63	5.50	.63x.31	27.50
441	0.69	53.41	51.66	1.00	27.50	48.50	13.19	29.96	55.00	0.75	5.50	.63x.31	27.50
491	0.69	59.31	57.56	1.00	28.50	54.25	14.63	33.40	57.00	0.78	5.50	.63x.31	27.50

SIZE	MC	ML	N	NH	NP	PC	PL	SD	SE	SP	TS	WW	MAX. MTR. FRAME
121	24.75	19.13	1.00	8	4	1.75	19.25	1.687	5.00	5.19	20.75	5.07	213T
141	26.25	20.13	1.00	8	4	1.75	19.25	1.687	5.00	5.19	20.75	5.67	215T
161	26.25	20.13	1.06	8	4	1.81	26.00	1.687	5.00	6.88	27.50	6.34	215T
181	29.50	24.13	1.06	16	4	1.81	26.00	1.937	5.50	6.88	27.50	7.24	254T
201	29.50	24.13	1.06	16	4	1.81	26.00	1.937	5.50	6.88	27.50	7.90	254T
221	29.50	25.50	1.13	16	4	1.88	28.25	1.937	5.50	7.44	29.75	8.80	256T
251	29.50	25.50	1.13	16	4	1.88	28.25	1.937	5.50	7.44	29.75	10.06	256T
281	31.50	26.63	1.25	16	6	2.25	32.13	2.187	6.00	5.69	34.13	11.25	284T
321	33.50	28.13	1.38	16	6	2.38	38.88	2.187	6.00	6.81	40.88	12.63	286T
351	33.50	28.13	1.38	16	6	2.38	38.88	2.437	6.50	6.81	40.88	14.19	286T
391	34.00	31.25	1.25	24	6	3.38	48.25	2.437	6.50	8.75	52.50	15.75	326T
441	36.00	31.25	1.25	24	6	3.38	48.25	2.687	6.50	8.75	52.50	17.63	326T
491	36.00	31.25	1.31	24	6	2.50	52.00	2.687	6.50	9.06	54.38	19.66	326T

Dimensions are not to be used for construction. Certified drawings are available upon request.

AC17170F

# Dimensional Data – Class III

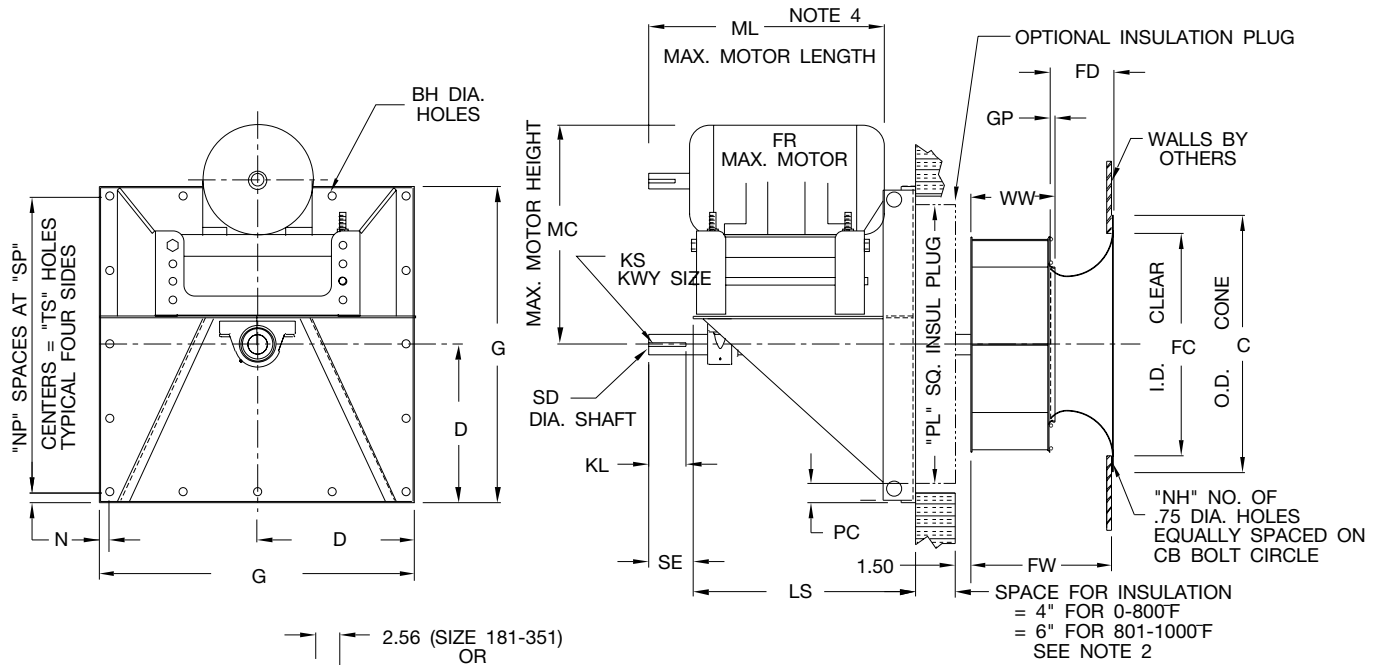

- NOTES:**
1. Dimensions apply to unboxed assembly only.
  2. When specified, the shaft length can be extended an additional 2 inches for 6 inches of insulation, for operation to 800°F, without changes to the shaft diameter. See Detail 'A' for details of recess cone for shaft cooler and shaft seal on fans over 300°F with 4 inches or larger insulation plug.
  3. CW rotation is standard. CCW rotation is optional.
  4. To insure selected motor will fit standard assembly, compare the maximum motor length, dimension "ML," to overall motor length.
  5. Dimensions are subject to change based on accessories. See page 14 for accessory options.
  6. Dimensions shown are in inches unless otherwise indicated.

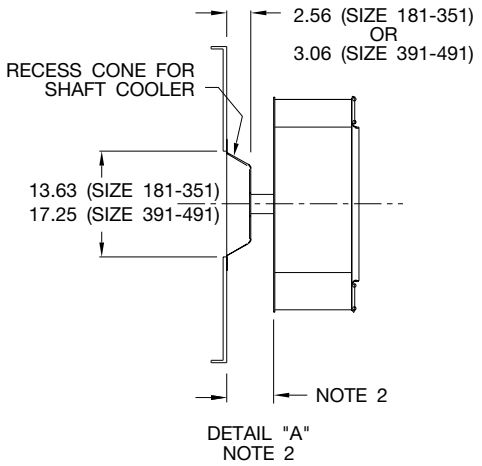

SIZE	BH	C	CB	CC	D	FC	FD	FW	G	GP	KL	KS	LS
181	0.56	22.84	21.56	0.88	14.81	20.00	5.31	12.24	29.63	0.31	4.50	.63x.31	25.00
201	0.56	25.19	23.94	0.88	14.81	22.00	5.88	13.46	29.63	0.31	5.50	.63x.31	27.50
221	0.56	27.97	26.69	0.88	16.00	24.50	6.59	15.08	32.00	0.31	5.50	.63x.31	27.50
251	0.56	31.13	29.84	1.00	16.00	27.50	7.44	16.93	32.00	0.50	6.00	.63x.31	30.50
281	0.69	34.66	33.38	1.00	18.31	30.75	8.38	19.12	36.63	0.50	6.00	.63x.31	30.63
321	0.69	39.59	37.84	1.00	21.81	35.00	9.44	21.46	43.63	0.56	6.50	.63x.31	32.38
351	0.69	43.53	41.78	1.00	21.81	39.25	10.63	24.15	43.63	0.63	8.00	.63x.31	37.88
391	0.69	48.31	46.53	1.00	27.50	43.50	11.75	26.83	55.00	0.63	8.00	.75x.38	38.38
441	0.69	53.41	51.66	1.00	27.50	48.50	13.19	30.09	55.00	0.75	8.00	.88x.44	38.38
491	0.69	59.31	57.56	1.00	28.50	54.25	14.63	33.46	57.00	0.78	8.00	.88x.44	38.38

SIZE	MC	ML	N	NH	NP	PC	PL	SD	SE	SP	TS	WW	MAX. MTR. FRAME
181	26.50	25.75	1.06	16	4	1.81	26.00	2.687	4.50	6.88	27.50	7.31	256T
201	28.00	28.88	1.06	16	4	1.81	26.00	2.687	5.50	6.88	27.50	7.97	284T
221	28.00	28.88	1.13	16	4	1.88	28.25	2.687	6.00	7.44	29.75	8.88	286T
251	32.00	32.00	1.13	16	4	1.88	28.25	2.687	6.00	7.44	29.75	10.06	324T
281	32.00	32.00	1.25	16	6	2.25	32.13	2.687	6.50	5.69	34.13	11.31	326T
321	34.00	34.38	1.38	16	6	2.38	38.88	2.687	8.00	6.81	40.88	12.69	365T
351	38.00	41.25	1.38	16	6	2.38	38.88	2.687	8.00	6.81	40.88	14.25	405T
391	38.00	41.25	1.25	24	6	3.38	48.25	2.937	8.00	8.75	52.50	15.81	405T
441	38.00	41.25	1.25	24	6	3.38	48.25	3.437	8.00	8.75	52.50	17.75	405T
491	38.00	41.25	1.31	24	6	2.50	52.00	3.437	8.00	8.75	54.38	19.72	405T

AC17171F

Dimensions are not to be used for construction. Certified drawings are available upon request.

# Dimensional Data – Accessories

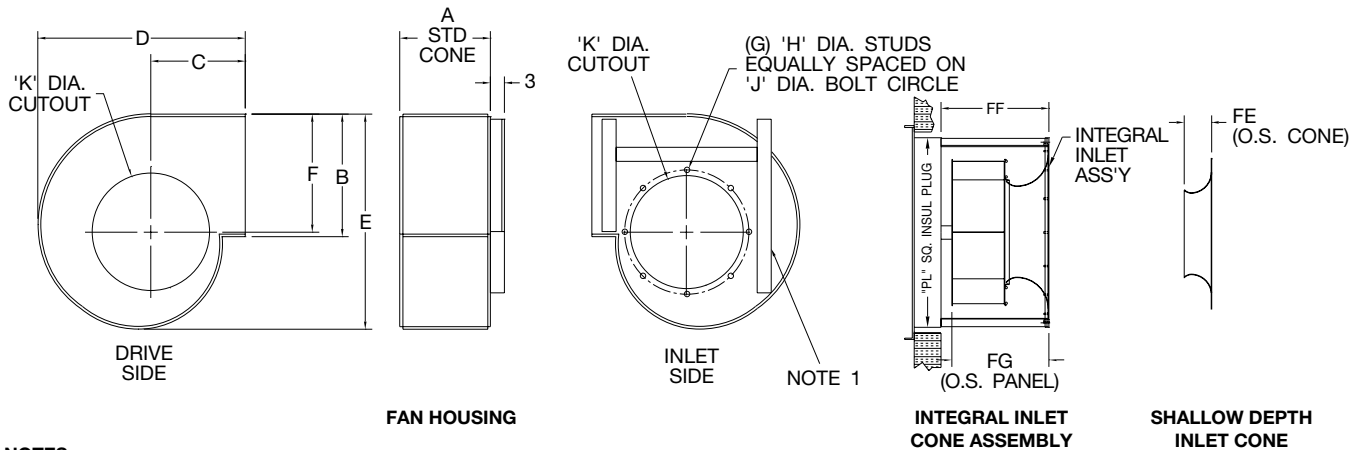

**NOTES:**

1. Inlet side frame angle on sizes 391, 441, and 491 only.
2. Dimensions shown are in inches unless otherwise indicated.

SIZE	A	B	C	D	E	F	G	H
121	10.00	13.81	12.56	25.13	23.69	13.19	8	3/8-16
141	11.00	15.63	13.69	27.88	26.69	14.88	8	3/8-16
161	12.19	17.56	14.81	30.81	30.00	16.75	8	3/8-16
181	13.63	19.75	16.13	34.13	33.75	18.81	16	3/8-16
201	14.88	22.00	17.50	37.50	37.50	20.88	16	3/8-16
221	16.44	24.69	19.00	41.38	42.06	23.44	16	3/8-16
251	18.38	27.75	20.81	45.94	47.25	26.31	16	3/8-16
281	20.44	31.25	23.94	52.25	53.25	29.63	16	3/8-16
321	22.81	35.19	26.44	58.38	59.88	33.38	16	3/8-16
351	25.50	39.56	29.44	65.31	67.38	37.50	16	3/8-16
391	28.13	43.94	29.56	69.44	74.88	41.69	24	1/2-13
441	31.25	49.25	32.63	77.25	83.88	46.69	24	1/2-13
491	34.69	54.94	35.88	85.69	93.50	52.06	24	1/2-13

SIZE	J	K	FE		FF		FG	
			STANDARD INLET CONE	SHALLOW INLET CONE	STANDARD INLET CONE	SHALLOW INLET CONE	STANDARD INLET CONE	SHALLOW INLET CONE
121	15.88	14.13	3.75	-	10.19	-	8.69	-
141	17.63	15.94	4.19	-	11.19	-	9.69	-
161	19.59	17.88	4.75	3.44	12.38	11.06	10.88	9.56
181	21.56	19.88	5.31	3.75	13.81	12.25	12.31	10.75
201	23.94	22.19	5.88	4.13	15.06	13.31	13.56	11.81
221	26.69	25.00	6.63	4.50	16.63	14.56	15.13	13.06
251	29.84	28.13	7.44	4.88	18.56	15.94	17.06	14.44
281	33.38	31.69	8.38	5.19	20.63	17.44	19.13	15.94
321	37.84	35.63	9.44	5.50	23.06	19.13	21.56	17.63
351	41.78	39.56	10.63	6.50	25.69	21.56	24.19	20.06
391	46.53	44.31	11.75	7.25	28.38	23.88	26.88	22.38
441	51.66	49.44	13.19	8.25	31.44	26.50	29.94	25.00
491	57.56	55.31	14.63	9.25	34.94	29.56	33.44	28.06

Dimensions are not to be used for construction. Certified drawings are available upon request.

AC17172D

# Belt Centers

MOTOR FRAME SIZE	CLASS II								CLASS III											
	121-161		181-251		281-351		391-491		181		201-221		251-281		321		351-391		441-491	
	MIN	MAX	MIN	MAX	MIN	MAX	MIN	MAX	MIN	MAX	MIN	MAX	MIN	MAX	MIN	MAX	MIN	MAX	MIN	MAX
56	13	16.5	14	17.5	14.5	18	16	19.5	9.4	13.4	9.4	13.4	9.3	13.3	9.3	13.3	9.3	13.3	9.8	13.8
143-145	13	16.5	14	17.5	14.5	18	16	19.5	9.4	13.4	9.4	13.4	9.3	13.3	9.3	13.3	9.3	13.3	9.8	13.8
182-184	14	17.5	15	18.5	15.5	19	17	20.5	10.4	14.4	10.4	14.4	10.3	14.3	10.3	14.3	10.3	14.3	10.8	14.8
213-215	14.8	18.3	15.8	19.3	16.3	19.8	17.8	21.3	11.2	15.2	11.2	15.2	11	15	11.1	15.1	11.1	15.1	11.6	15.6
254-256	—	—	16.8	20.3	17.3	20.8	18.8	22.3	14.8	18.8	14.8	18.8	14.6	18.6	14.7	18.7	14.7	18.7	15.2	19.2
284-286	—	—	—	—	18	21.5	19.5	23	—	—	15.6	19.6	15.4	19.4	15.4	19.4	15.4	19.4	15.9	19.9
324-326	—	—	—	—	—	—	20.5	24	—	—	—	—	17.6	22.6	17.6	22.6	17.6	22.6	18.1	23.1
364-365	—	—	—	—	—	—	—	—	—	—	—	—	—	—	18.6	23.6	18.6	23.6	19.1	24.1
404-405	—	—	—	—	—	—	—	—	—	—	—	—	—	—	—	20.8	25.8	21.3	26.3	—

# Typical Specifications

---

Fans shall be Type BFPL Single Thickness Airfoil, as manufactured by Twin City Fan & Blower, Minneapolis, Minnesota.

**PERFORMANCE** — Fans shall be tested and rated in accordance with industry accepted test codes and shall be guaranteed by the manufacturer to deliver rated published performance levels.

**PLUG PANEL** — Plug panel shall be of minimum 7 gauge steel with formed flanges to maintain flatness and rigidity. Panel shall be prepunched for bolt mounting. The "Cross Frame" bearing support shall be designed for maximum stability and load spreading. Bearings shall be serviceable without disassembly of panel or frame. Plug assembly is available for both horizontal and vertical application. Horizontal construction is standard. Vertical construction must be specified.

**WHEEL** — BFPL wheels shall be backward curved, non-overloading, single thickness airfoil type, designed for maximum efficiency and quiet operation. Wheels shall be constructed of heavy gauge steel, continuously welded to a flat wheel cone and backplate. Partial welding will not be acceptable.

**SHAFT** — Shafts shall be AISI 1040 or 1045 hot rolled steel accurately turned, ground, polished, and ring gauged for accuracy. Shafts shall be sized for a first critical speed of at least 1.43 times the maximum speed for the class.

**BEARINGS** — Bearings shall be either ball or spherical roller, heavy duty, self-aligning, pillow block type. Bearing selection is based upon L-10 minimum life of 40,000 hours or L-50 minimum life of 200,000 hours.

**OPTIONAL ALL WELDED HOUSING** — Housing shall be of heavy gauge steel. Housing shall be provided with wheel opening on each side and weld studs on inlet side for cone mounting. Specify rotation and discharge as viewed from drive side to insure proper stud placement. Housing supports and attachments for wall mounting to be provided by others.

**ADJUSTABLE MOTOR BASE** — Adjustable motor base is standard and shall have a four point leveling and tension adjustment to insure proper drive belt alignment. The motor base shall be heavy gauge steel and prepunched to accept standard motor frame specified.

**OPTIONAL INLET VANES** — Inlet vane blades are cantilever design or with centered supports equipped with permanently lubricated needle bearings and ball joints for smooth and easy operation. Vane assemblies are external type for sizes 121 through 161 and nested for sizes 181 through 491. Standard inlet vanes are applicable to 300°F. Consult factory for higher temperatures.

**FACTORY RUN TEST** — All fans prior to shipment shall be completely assembled and test run as a unit at the specified operating speed or maximum RPM allowed for the particular construction type. Each wheel shall be statically and dynamically balanced in accordance with ANSI/AMCA 204-96 "Balance Quality and Vibration Levels for Fans" to Fan Application Category BV-3, Balance Quality Grade G6.3. Balance readings shall be taken by electronic type equipment in the axial, vertical, and horizontal directions on each of the bearings. Records shall be maintained and a written copy shall be available upon request.

**GUARANTEE** — The manufacturer shall guarantee the workmanship and materials for its BFPL Single Blade Airfoil Plug Fans for at least one (1) year from startup or eighteen (18) months from shipment, whichever occurs first. Fans shall be Type BFPL Single Thickness Airfoil, as manufactured by Twin City Fan & Blower, Minneapolis, Minnesota.

# Unlimited Options...

## Commercial Fans

Centrifugal Fans • Utility Sets • Inline Centrifugal Fans • Plenum Fans  
Radial Bladed Fans • Centrifugal Roof & Wall Exhausters • Filtered Supply Fans  
Gravity Relief Ventilators • Ceiling & Cabinet Ventilators • Propeller Wall Fans  
Tubeaxial Fans • Vaneaxial Fans • Propeller Roof Ventilators  
Fume Hood/Smoke & Heat Exhaust Fans • Mancoolers • Fiberglass Fans

## Industrial Fans

Centrifugal Fans • Forward Curved & Air Kit Components • Inline Centrifugal Fans  
Plug Fans • Radial Bladed Fans • Radial Tip & High Efficiency Fans  
Pressure Blowers • Tubeaxial Fans • Vaneaxial Fans

## Custom Design Fans

Easy Access Fans • Insulated Fans • Inlet Boxes - Integral and Detached  
Inlet Box Dampers • Independent Bearing Pedestals • Split Housings • Bolted Housings  
Spark Resistant Construction • Ultra Fine Balancing • Modified Widths and Diameters  
Variable Frequency Drives • API Specifications • Special Materials • Anti-Rotation Devices  
Sleeve Oil Bearings • Volume Control Dampers • Inlet Vane Control with External Mechanisms

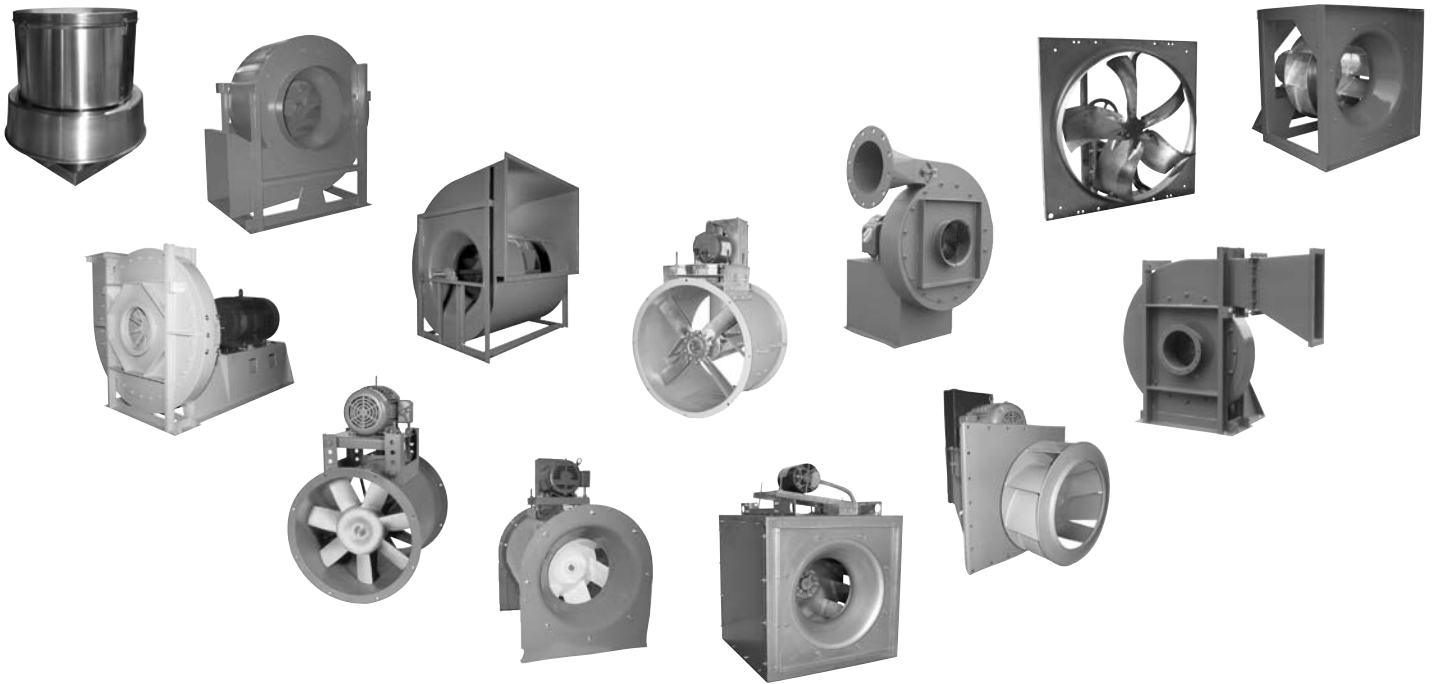

# ...One Solution.



5959 TRENTON LANE NORTH • MINNEAPOLIS, MN 55442-3237

PHONE: 763-551-7600 • FAX: 763-551-7601

WWW.TCF.COM